

QUICK-UP PUSH AROUND MANLIFTS

TECHNICAL DATA

	QUICK-UP 7	QUICK-UP 8	QUICK-UP 9	QUICK-UP 12
Working height	6.7 m	8.1 m	9.5 m	12.3 m
Platform height	4.7 m	6.1 m	7.5 m	10.3 m
Lift capacity	159 kg	159 kg	159 kg	136 kg
Platform size	0.68 x 0.66 m	0.68 x 0.66 m	0.68 x 0.66 m	0.68 x 0.66 m
C Length	1.22 m	1.28 m	1.28 m	1.4 m
D Width	0.8 m	0.8 m	0.8 m	0.8 m
A Height - stowed	1.78 m	1.98 m	1.98 m	1.98 m
I Width - stabilised	1.55 m	1.55 m	1.55 m	2.06 m
H Length - stabilised	1.75 m	1.75 m	1.75 m	2.26 m
J x B Tilt bar	N/A	N/A	N/A	N/A
Energy (DC)	12 V	12 V	12 V	12 V
Weight (DC)	357 kg	382 kg	402 kg	457 kg

STANDARD EQUIPMENT

- Easy to use thanks push button controls
- Emergency control
- Manual platform lowering valve
- Integrated forklift pockets
- Lifting eye
- Non marking wheels
- Harness attachment point
- Lights on control box to confirm stabilizers are set

A wide range of machines to meet your every need

- Working heights from 7 to 12 m
- 2 available versions supply-power (AC) or batteries (DC)

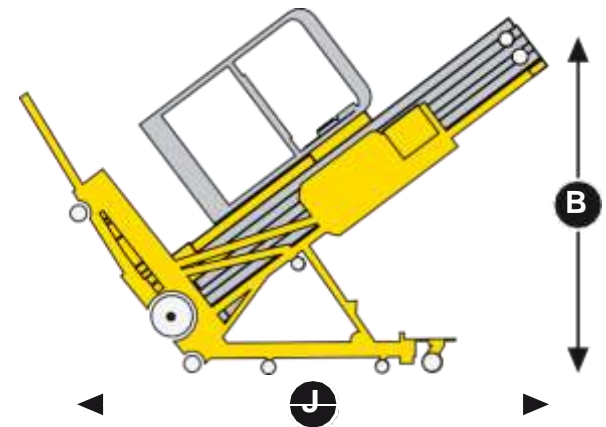
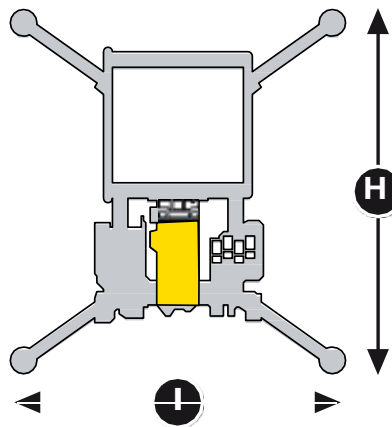
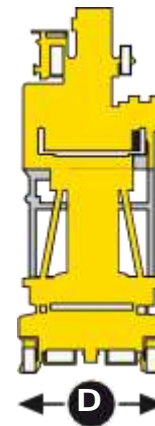
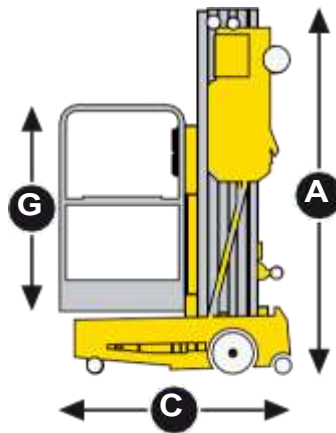

The Quick-Up will follow you on every project

- Easy to transport on a trailer or van
- Only one person is needed to install a Quick Up
- The light weight enables use on fragile grounds, tiles, carpeting...
- Quick up are extremely compact, they can access the tightest spaces, fit through standard doorways and can be transported in lifts